

**SCRAMBLER
DUCATI**

CITY CROSS-E

electric scooter

Street edition - Total Black

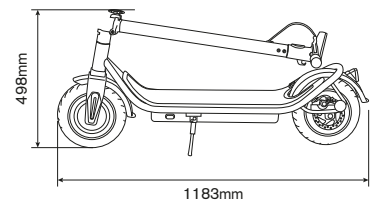
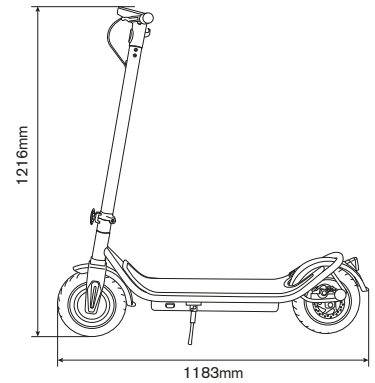

10" Street tubeless tyres



Integrated LED display



Rear disc brake

Technical specifications

Product Sku: **MN-DUC-SCCB**
Ean Code: **8052870483867**

Basic info	
Frame material	aluminium alloy
Speed	ECO: <= 6km/h D:<= 20km/h S: <= 25km/h (max speed)
Maximum gradient	15%
Brakes	double brake: front electronic and rear disc brakes
Motor Power	350W
Tyres	10" Road tubeless tyres
Low voltage protection	31V +/- 0.5V
Current limit	13-15A
Motor type	brushless
Max load	120kg
Riding Requirements	Consult the laws and regulations currently in force in your country.*
Working Temperature	-10°C / 50°C
Level of protection	IPX5
Charging time	about 6/7 hours
Autonomy	up to 45km (subject to be variable by rider weight, road condition, temperature etc.)

Electric system	
Motor	350W brushless
Brakes	front electronic brake
Display	LED display integrated
Battery	36V, 12.8Ah, 461Wh
Lights	Front and rear LED lights
Charger	EU Standard DC2.1 Charger, 42V 2A

Dimensions and Weights	
Net weight	19kg
Gross weight	23kg
Unit size	1183 x 460 x 1216mm
Folding size	1183 x 460 x 498mm
Carton size	1200 x 240 x 550mm

*In Italy this subject is currently disciplined by the law L 27/12/2019 N.160